

C.A.R.D.[®] MODEL 060

INSTALLATION AND OPERATION MANUAL



SURVIVAL SAFETY ENGINEERING INCORPORATED

**321 NAVAL BASE ROAD
NORFOLK, VIRGINIA 23505
USA**

Phone (757) 480-5508 Toll Free 888 475-5364

Email: survivalsafety@cox.net

www.survivalsafety.com

CONGRATULATIONS

You have just purchased one of the most important devices you will ever buy for your vessel.

®

C.A.R.D. Model 060, Collision Avoidance Radar Detector is the finest Radar Detector on the market today.

It uses the same detector principles as the Model 100 Units that have performed so well under rigorous conditions for the U.S. Navy.



WARNING !

This device is intended for use as an aid to collision avoidance only. It does not in any way, relieve or reduce the responsibility of the Captain of the vessel for maintaining a proper watch at all times when underway as described in the Code of Federal Regulations and International Maritime Law.

C.A.R.D. SYSTEM COMPONENTS

The Antenna with a standard 25 foot cable

The Display Unit (Control Module)

This Manual

INDEX:

Warning	Page 2
Components	Page 3
How your C.A.R.D. system works	Page 4
Antenna Installation	Page 5,6
Antenna Unit	Page 7
Control Module Warning	Page 8
Control Module	Page 9
Operation	Page 10,11
Remote	Page 11
Pin Out	Page 12
Test	Page 13
Notes	Page 14
Warranty	Page 15

HOW YOUR C.A.R.D. SYSTEM WORKS

The antenna portion of the unit has four directional receivers that correspond to the four relative display lights on the control unit. A ship operating radar in a frequency from 3 to 10 centimeters emits a stream of microwave pulses as their antenna rotates. When these pulses strike one or more of the detectors in the C.A.R.D. antenna, they are processed to light up the corresponding display. The intensity of the signal will determine the number of lights that will be illuminated.

When the top light bar (zero degrees relative bearing lights), it tells you that a target is off your bow, when the light bar at three O'clock (ninety degrees relative bearing lights), it tells you that a target is on your starboard beam. If both top and three O'clock light bars go on simultaneously and the same number of lights within the bar are illuminated, they tell you that your target is approximately 45 degrees off your starboard bow, and so on around the display.

The **C.A.R.D.** Radar Detector cannot determine the distance a scanning ship is away from your vessel, but since radar pulses are microwaves that travel in straight lines, the maximum range is a factor of the height of the ship's radar and your vessel's antenna. Remember that more than one ship can be scanning your vessel at the same time. Experience with your **C.A.R.D.** System will quickly enable you to recognize the characteristics of different situations.

Your Radar Detector can be safely operated at the same time your own radar is scanning, provided the the detector's antenna is installed correctly. The **C.A.R.D.** antenna may **NOT** be installed next to your radar antenna or at the same height. It is best to find a location as distant as possible from any transmitting antennas. It is possible that pulses from your own radar could activate the Radar Detector by reflecting off nearby obstacles on your vessel as well as other ships or nearby coast lines.

INSTALLATION

Unit Installation

If you chose to have someone install the **C.A.R.D.** system for you, ensure that this manual is available to them. It contains important installation information which may or may not be familiar to the service personnel. Save this manual for future reference.

Technical Support Group is at your service anytime at:

1- 888 - 475 -5364

ANTENNA

The **C.A.R.D.** system antenna unit should be mounted so as to be free of obstructions as possible . The antenna should be oriented with the vessel so that the cross-hair labeled **FWD** on the antenna dome is pointing toward the bow of the vessel and if not on the vessel's centerline, parallel with the centerline of the vessel . The unit should be mounted with the base of the antenna down. Mounting the antenna upside down will result in the alarm displayed on the opposite side of the vessel on the display unit . If such a mounting procedure is applicable to your needs, contact Survival Safety Engineering for technical assistance.

When choosing a location for the mounting the **C.A.R.D.** System Antenna ensure that the mounting surface has adequate strength to support the antenna. Check the area for possible obstructions, both to mounting and to reception.

Make sure that the antenna will not be mounted in the beam path of an existing radar or mounted so that it might interfere with installation and operation of a radar in the future. One of the best locations is on the stern rail. This can be accomplished with a rail mount and a short extension. Raise the antenna above the cabin top to clear as many obstructions as possible.

For the antenna cable installation, you have three options :

- 1) Determine a cable route that does not require deck penetration;
or
- 2) Cut the cable to permit deck penetration , and rejoin the cable using NEWMAR splash proof junction box Model BX-1 or equivalent available at your local marine supply store;
or
- 3) If you choose not to cut the cable, you may use a waterproof cable feed-through deck fitting for use with cable with installed cable connector, NEWMAR Model CCX-P or equivalent, also available at your local marine supply store.

Ensure that the antenna unit will be adequately protected from lines that may foul on the unit and either damage the cable or the antenna unit.

Plan a route for the connecting cable to the display unit, ensuring the cable is of adequate length to reach the rear of the display unit without putting tension on the cable. Also insure the cable is fastened securely so it will not become caught in nearby machinery. Try to avoid running the connecting cable in close proximity to power cords or generators carrying alternating current. The recommended procedure is to temporarily install all components of the antenna on the vessel in the planned positions. Check to ensure the unit functions properly and receives only minimal interference from other transmitting equipment, including any marine band or CB radios on the vessel.

If the location proves to be inadequate due to interference, find another more suitable location. If the location proves to be adequate, attach it permanently in position . This is accomplished by fastening the antenna unit base securely to the mounting surface , and then securing the antenna unit to the base .

Most threaded antenna mounts are accepted by the base . Secure the connecting cable along the planned route so as to not interfere with anything.

ANTENNA

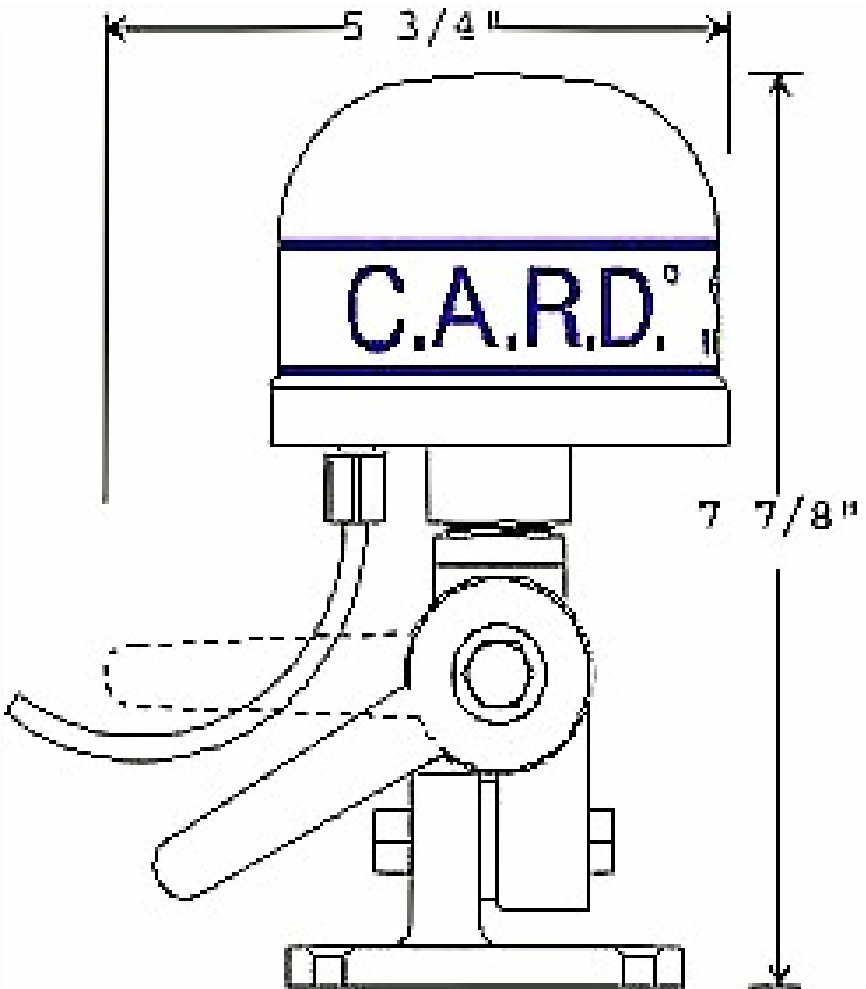

Stern Rail Mount preferred

Antenna Mounts available at most marine stores

CONTROL MODULE



WARNING

The Display Module **IS NOT WATER RESISTANT !**

When choosing a location find one that remains dry.

Your navigation station should qualify.

Mount the control module in a convenient location where you can observe the display .

Connect the power cable to a reliable power source of 12 volts D.C..

It is suggested that you run the power cable to your distribution panel and not parallel to any other circuits .

Connect the red wire to positive and the black wire to the ground.

For further protection a 1/4 amp fuse can be installed either in line or at the distribution panel.

DISPLAY CONTROL MODULE

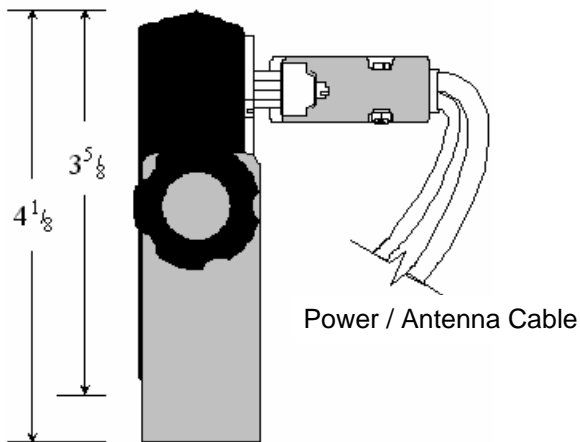
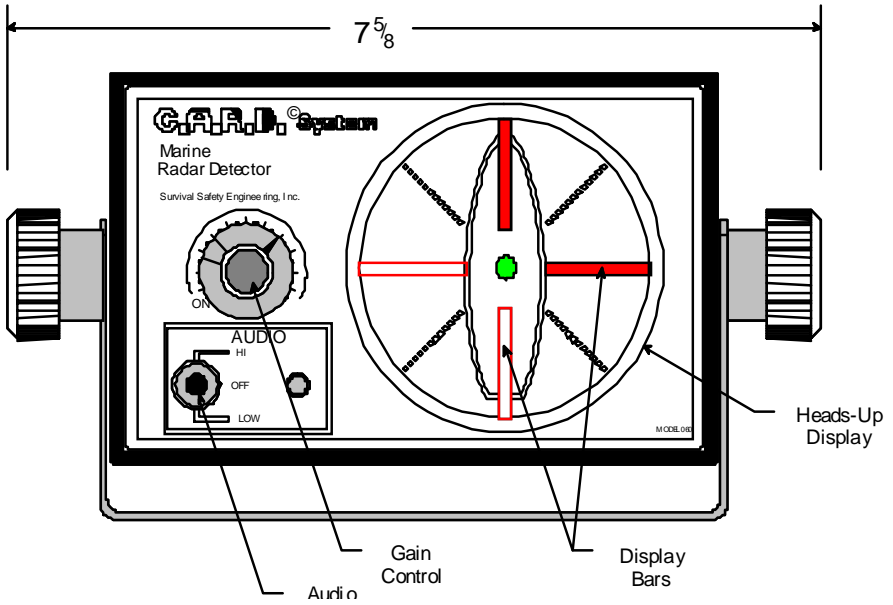

OPERATION

The control panel has a dial that when turned clockwise will activate the system and sets the level of sensitivity. The toggle switch will select the level of audio desired.

Since radar transmissions travel line-of-sight, the distance at which a target is detected is dependent primarily on two factors : the height of the transmitting antenna and the height of your receiving antenna... Thus, if the **C.A.R.D.** antenna is mounted on your stern rail and has an unobstructed view of 5 to 15 miles you should receive an indication if there are any radar emitting ships in the area.

Another factor affecting range is the power of the other ship's transmitting radar. **Do not assume** that a weak signal is distant and a strong signal is close. A very powerful radar several miles away can be of equivalent signal straight as a small radar on a low range setting. Keeping in mind the fact that a **C.A.R.D.** does not finitely measure range, overall range reception is adjustable by changing the sensitivity control knob.

Although, as this discussion indicates, a specific maximum range cannot be determined without knowing all the factors, experience has shown that approximate ranges of 35 miles are attainable. You should also bear in mind the visual distance to your horizon is also a function of your height of eye. Therefore it will serve a little useful purpose to detect a ship at 30 miles if it never closes to within your visual sighting range, let alone becomes a collision threat .

It is also important to note that a powerful transmitting Radar Unit fairly close aboard will saturate the system, however, by rotating the sensitivity knob clockwise, a more accurate direction can be determined.

Further, if you are transiting near a steep coastline and are illuminated by a ship outboard of you, you may get an indicator

light from the signal reflected from the coast as well as one from the primary source. Again, by rotating the sensitivity knob a few degrees clockwise, the reflected signal should disappear.

REMOTE HORN

A remote horn can be installed using the pin #7 of the antenna plug.

Remove the shell covering plug.

Locate pin #7 (this is the only one without a wire).

Connect a wire to the negative side of the buzzer.

The positive side of the buzzer is connected to the positive side of your battery.

We recommend that you install an on-off switch in the 12 volt line, to turn off the remote when not needed.

For help with this installation please call SSE for assistance at:

1 - 888 - 475-5364

Voice: 757 - 480-5508

www.survivalsafety.com
survivalsafety@cox.net

PIN OUT

Pin	# 1	Red	(B= to the antenna)
	# 2	Blue	Aft Detector
	# 3	White	Stbd Detector
	# 4	Green	Port Detector
	# 5	Brown	Fwd Detector
	# 6	Black	Power B-
	# 7	NC	Negative for external alarm
	# 8	Red	Power B+
	# 9	Black	(B- to the antenna)

TEST

Double check that all connections are secure and are set up according to the instructions. Turn the sensitivity control knob clockwise until all segments of the display are lit, then continue to turn the sensitivity control clockwise until all the indicator lights go out. The point where the lights just extinguish is the point of the highest sensitivity. This is much like setting the squelch on a VHF Marine Radio. If a light stays on steadily, it indicates that the sensitivity adjustment knob on the control module is set too high, or there is a fault within the system.

Should you experience a problem with your C.A.R.D. System, please call Survival Safety Engineering directly. We have personnel that are specifically trained to help you at.

1- 888 - 475 - 5364

Safe Sailing ,

The Crew at Survival Safety Engineering

NOTES

WARRANTY
Survival Safety Engineering, Incorporated
Two Year Limited Warranty

Every Survival Safety Engineering (SSE) C.A.R.D. Model 060 is thoroughly inspected and tested before leaving the factory. It is warranted to be free of defects from workmanship and materials for the period of TWO YEARS from the date of original purchase. Should any trouble develop during this two year period, return the COMPLETE unit, freight prepaid, to the company at: 321 Naval Base Road, Norfolk, Virginia 23505. If inspection shows the trouble is caused by defective workmanship or material, SSE will repair, or at our option, replace without charge.

This Warranty does not apply where:

- ◆ repairs have been made or attempted by others
- ◆ repairs are required because of normal wear and tear
- ◆ the unit has been abused, misused or improperly installed
- ◆ alterations have been made to the unit

In no event shall SSE be liable for any indirect, incidental or consequential damages from the sale or use of the unit. This disclaimer applies both during and after the term of warranty.

SSE disclaims liability for any implied warranties, including implied warranties of “merchantability” and “fitness for a specific purpose”, after the two year term of this warranty.

Some states do not allow the exclusion or limitation of incidental or consequential damages, so the above limitation or exclusion may Not apply to you.

